

HOT - LED Oven lamp, Square

77.116 · LED oven lamp for rectangular cutouts 120 x 25 mm

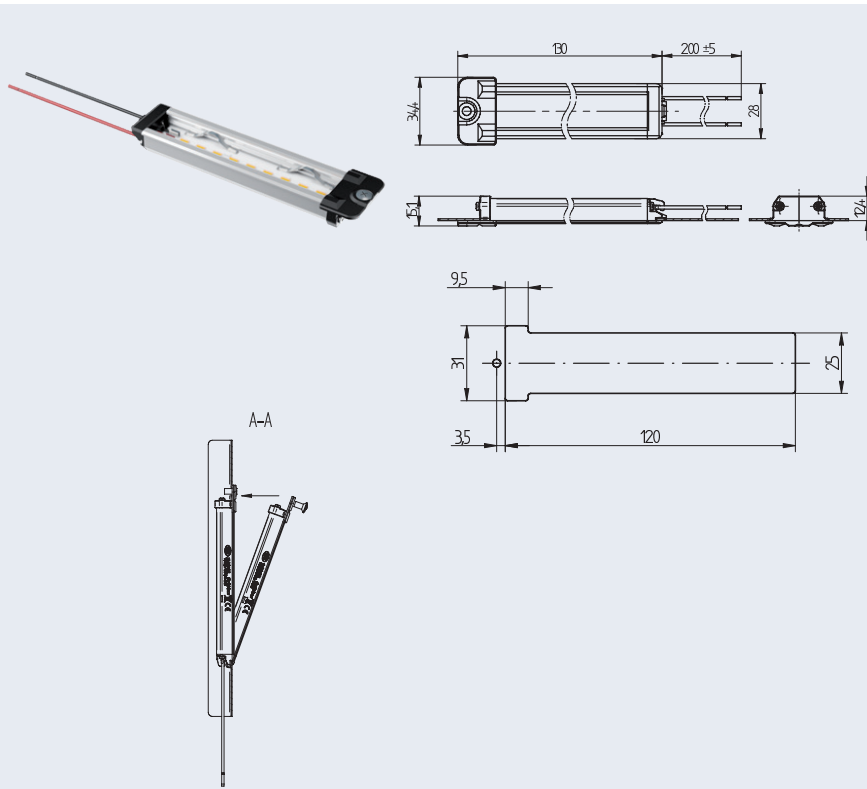

pkg. wt. part no.
216 52 g 77.116.1010.36

LED oven door lamp

- Easy installation by swivel-screw fixing
- Symmetric light distribution for optimised illumination of the oven muffle

Material thickness: 0.5 - 1.0 mm

- Variable LED parameters (CCT, CRI, number)
- Protection class III due to operation on SELV voltage
- max. possible current flow of the luminaire is to be most unfavorable operating condition to be determined
- The selection of our products, as well as the technically installation in accordance with the relevant regulations (e.g. IEC 62031 and IEC 60335) are the responsibility of the user.

Photometric data	
Number of LEDs	9
Luminous flux @Ta25° C @ If typical	300 lm
Colour temperature	3.000 K
Colour Rendering Index CRI	> 80
Colour tolerance	< 3.5 SDMC
Beam angle	120°
Temperature data	
Max. temperature @ Tc point of heat sink	100° C
Electrical data	
Operating mode	Constant voltage
Operating current If	295 mA
Operational voltage Uf	12 V
Power consumption	3.5 W
Efficiency	85.7 lm / W
Dimmable	No
Materials	
Heat sink	Aluminium
End caps	PET
Wires	PVC 0.35 mm ² , 200 mm
Wire ends	with ferrule
Protective glass	Borosilcate, frosted
Average life span (L70 / B50)	50.000 h (according to BJB test requirements)

Tolerances of optical and electrical data: ±10 %.

Symmetric light distribution

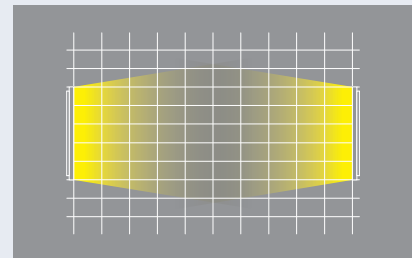

EOS/ESD safety guidelines

Some components of the BJB /// OEM – Line Modular System might be harmed by electrostatic discharge (ESD) and electrical overstress (EOS) and may only be installed in the factory and on site if appropriate EOS/ESD protection measures have been taken.

Modules where no contact to the LED module is possible do not need special measures for protection of electrostatic discharge (ESD).

Assembly instructions

The LED module may be exposed to tensile or compressive stresses.

Note to chemical reactions

Chemical substances may harm the LED module. This could lead to reduced luminous flux, colour shift or total failure of the module caused by corrosion of electrical connections. Avoid corrosive atmosphere during usage and storage.

Life span and lumen maintenance

The light output of an LED module decreases over the life-time, this is characterized with the L value.

L70 means that the LED module will give 70 % of its initial luminous flux. This value is always related to the number of operation hours and therefore defines the lifetime of an LED module. As the L value is a statistical value and the lumen maintenance may vary over the delivered LED modules.

Thermal design, tc point, ambient temperature and life-time

The rated life of a LED module depends to a large extent on the temperature. If the permissible temperature limits are exceeded, the life of the LED module will be greatly reduced or the module may be destroyed.

The temperature at tc reference point is crucial for the light output and life-time of a LED module.

Electrical supply

- The LED modules have no special protection against overvoltage, overcurrent, overload or short-circuit currents.
- To ensure reliable and safe operation a converter must be used which corresponds to the relevant regulations
- The BJB LED modules can be operated on SELV converters.
- The use of converters that provide constant current, permanent damage may occur.
- Wrong polarity may cause damage to the BJB LED components..