

SMD-Terminal block

46.121 · Push through Terminal block - M



technology for light

SMD-Push through terminal block with push wire contacts

1 pole - 46.121.1002-0

Direct insertion of solid and stranded, tinned wire ends

Wires can be released by twisting and pulling the wire simultaneously.

Mounting and wiring position: PCB bottom side

Ballast and PCB terminal block on one level

Machine-compatible "tape-and-reel" packaging

Fixing: Lead-free reflow soldering according to DIN EN 610760-1, section 6

Material: Housing: PPA, white
Contact material: CuNi
Contact surface: hot-dip tinned

Packaging data 46.121.1002-0	
Weight per piece	0.5 g
Pieces per coil	1.400
Coil diameter	381 mm - (15")
Weight per coil	1.06 kg
Number of coils per carton	10
Number of SMD terminal blocks per carton	14.000
Weight per carton	11.79 kg
Carton dimensions (LxWxH)	400 x 405 x415 mm

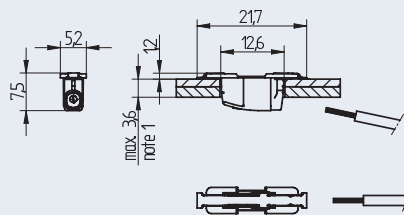

Note 1: Maximum thickness of PCB and luminaire heat sink shall not exceed 3.6 mm.

General note: It is recommended to make an electrical connection between both poles of each polarity on the solder pad.

Recommended dimension for opening in PCB

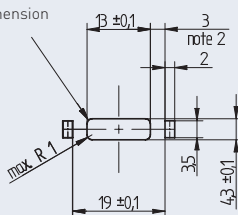

Note 2: The minimum creepage distance has to be guaranteed, depends on the application.



Connection data	
Connection technology	Push wire contacts
Solid wires	0.2 - 0.75 mm ² , AWG 24-18
Stranded, tinned wires	0.2 - 0.5 mm ² , AWG 24-20
Strip length	8 +1 mm
Conductor entry angle to the PCB	0 - 10°
Wire release function by	Twisting and Pulling

Pull-out force according to DN 60999-1	
0.2 mm ²	min. 10 N
0.34 mm ²	min. 15 N
0.5 mm ²	min. 20 N
0.75 mm ²	min. 30 N
Insertion force	max. 10 N

Geometrical data	
Pin spacing	5.25 mm / 0.206 inch
Width	5.2 mm / 0.204 inch
Height	7.5 mm / 0.295 inch
Depth	21.7 mm / 0.85 inch

Material data	
Insulating material group	I
Insulating material	PPA, white
PTI	600
Flammability class, based on UL UL 94	V-0
Contact material	CuNi
Contact surface	hot-dipped tinned

Mechanical data	
Mounting position	PCB bottom side
Mounting type	Lead-free reflow soldering

Temperature data	
Marginal temperatures	-70 °C to + 150 °C
Ambient temperature	-70 °C to + 125 °C
T-classification according to IEC 60998-1 para. 12	120° C

Rated data according to IEC / EN 60947-7-4 (IEC/EN 60664-1) for PCB type FR4 1.0 mm	
Rated voltage (III / 3)	200 V
Rated impulse voltage (III / 3)	2.5 kV
Rated voltage (III / 2)	250 V
Rated impulse voltage (III / 2)	2.5 kV
Rated voltage (II / 2)	400 V
Rated impulse voltage (II / 2)	2.5 kV
Rated current	9 A

Rated data according to IEC / EN 60947-7-4 (IEC/EN 60664-1) for PCB type IMS	
Rated voltage (III / 3)	63 V
Rated impulse voltage (III / 3)	2.5 kV
Rated voltage (III / 2)	160 V
Rated impulse voltage (III / 2)	2.5 kV
Rated voltage (II / 2)	320 V
Rated impulse voltage (II / 2)	2.5 kV
Rated current	9 A

Rated data according to UL 1977 / CSA-C22.2 No. 182.3	
Rated voltage UL 1977	600 V
Rated current UL 1977	USR 9 A, AWG 24 -18 CNR 6 A, AWG 24-20 CNR 9 A, AWG 18

Country specific certificates	
VDE / ENEC	EN IEC 60947-7-4 File no.: 40040866
cURus	UL 1977 / CSA-C22.2 No. 182.3 File no.: E-365006

Shear forces according to IEC 62137-1-2.	
These values are maximum values that apply only for impuls, not for continuous load.	
Direction 1 shear force along	100 N
Direction 2 shear force along	80 N
Direction 3 shear force across	20 N
Direction 4 shear force across	20 N
Direction 5 pull-off force	20 N

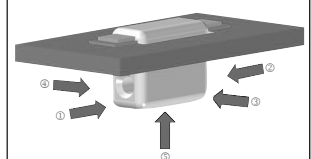

Instructions for soldering process

Suitable for leadfree-reflow-profiles according to DIN EN 61760-1 respective DIN EN 60068-2-58 up to peak-temperature of max. 260°C. Due to different application-specific parameters (component arrangement and alignment, soldering system, solder paste), it is recommended to use test runs to determine a suitable profile under production conditions.

Depending on the SMD soldering process and associated parameters a minor discoloration might occur. However, this will not influence the functionality.

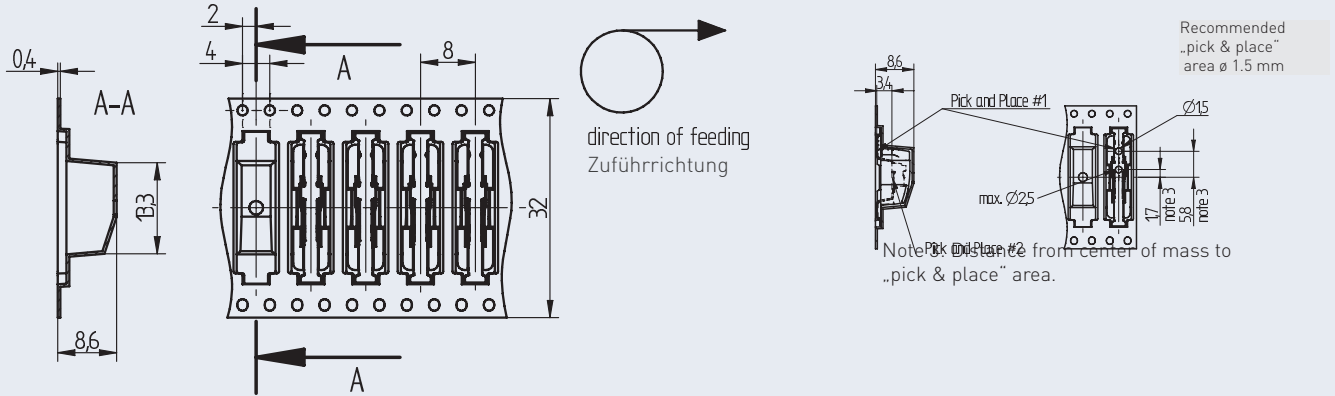

Storage time	Solderability up to 6 months when stored between -5°C and +40°C and rel. humidity between 10...60% r H. After a storage time of 6 months, solderability has to be checked according to J-STD-002D or DIN EN 60068-2-58:2016.
max. allowed number of reflow-processes	3
Reflow-profile	<p>Reflow-profile (lead-free)</p>
Solderability	Solderability of components is checked by wetting test according to J-STD-002D
Assembly method	SMD, according to drawing
Recommended solder stencil thickness	100 - 150 µm (recommendation BJB 150 µm)