

HOT- LED oven lamp, Square

77.115 · LED oven lamp with light conducting glass rod and reflector 30 x 70 mm

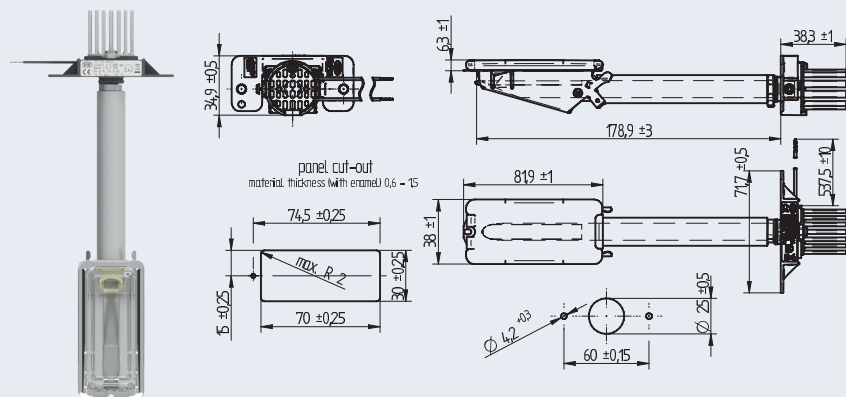

pkg. -- wt. 102 g part no. 77.115.8701.10

LED oven light with Glass light guide rod and reflector

Symmetrical light characteristic

Reflector and oven light are supplied separately.

Screw fastening: for M3 screws alternative
Fastening with BJB P2F fastening element 28.905

- Due to the variable length of the light conduction glass rod and the protective tube, different installation heights in the unit can be handled without any problems.

- Variable LED parameters (CCT, CRI, number) are possible
- Protection class III due to operation on SELV voltage
- max. possible current flow of the luminaire is to be most unfavorable operating condition to be determined
- The selection of our products, as well as the technically installation in accordance with the relevant regulations (e.g. IEC 62031 and IEC60335) are the responsibility of the user.

Special designs with higher requirements such as steam tightness, with microwave shielding or pyrolysis suitability on request.

Photometric data	
Number of LEDs	1
Lichtstrom @Ta25° C @ If typisch	--
Color temperature	--- K
Color rendering index (CRI)	> 80
Temperature data	
Max. temperature @ Tc-point of heat sink	110° C
Electrical data	
Operating mode	Constant current
Operating current If	1.000 mA
Output	6.0 W
Dimmable	yes, with suitable ballast
Material specifications	
Heat sink	Aluminum, anodized
Housing	PET
Light conducting glass rod and cover	Borosilicate glass
Reflector	Steel, Aluminium plated
Protective tube	Aluminum, anodized
Average life time (L70 / B50)	5.000 h (according to BJB test requirements)

Tolerances of optical and electrical data: ±10 %.

Installation position

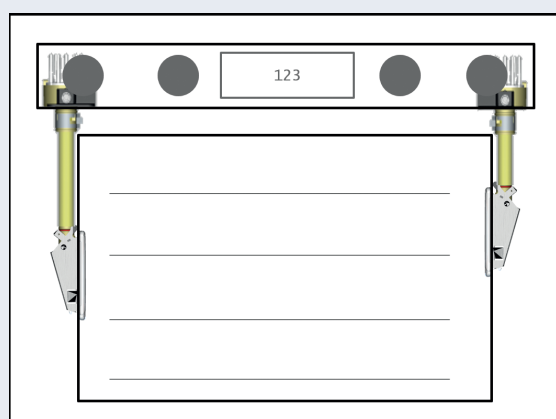

EOS/ESD safety guidelines

Some components of the BJB /// OEM – Line Modular System might be harmed by electrostatic discharge (ESD) and electrical overstress (EOS) and may only be installed in the factory and on site if appropriate EOS/ESD protection measures have been taken.

Modules where no contact to the LED module is possible do not need special measures for protection of electrostatic discharge (ESD).

Assembly instructions

The LED module may be exposed to tensile or compressive stresses.

Note to chemical reactions

Chemical substances may harm the LED module. This could lead to reduced luminous flux, colour shift or total failure of the module caused by corrosion of electrical connections. Avoid corrosive atmosphere during usage and storage.

Life span and lumen maintenance

The light output of an LED module decreases over the life-time, this is characterized with the L value.

L70 means that the LED module will give 70 % of its initial luminous flux. This value is always related to the number of operation hours and therefore defines the lifetime of an LED module. As the L value is a statistical value and the lumen maintenance may vary over the delivered LED modules.

Thermal design, tc point, ambient temperature and life-time

The rated life of a LED module depends to a large extent on the temperature. If the permissible temperature limits are exceeded, the life of the LED module will be greatly reduced or the module may be destroyed.

The temperature at tc reference point is crucial for the light output and life-time of a LED module.

Electrical supply

- The LED modules have no special protection against overvoltage, overcurrent, overload or short-circuit currents.
- To ensure reliable and safe operation a converter must be used which corresponds to the relevant regulations
- The BJB LED modules can be operated on SELV converters.
- The use of converters that provide constant voltage, permanent damage may occur.
- Wrong polarity may cause damage to the BJB LED components..